

Understanding EPO and Its Downtime Risks

White Paper 22

Revision 3

by Stephen McCluer

> Executive summary

An Emergency Power Off (EPO) system is intended to power down a single piece of electronic equipment or an entire installation from a single point by activating a push button. EPO is employed in many applications such as industrial processes and information technology (IT). This white paper describes the advantages and disadvantages of EPO for protecting data centers and small IT equipment rooms containing uninterruptible power supply (UPS) systems. Various codes and standards that require EPO are discussed. Recommended practices are suggested for the use of EPO with UPS systems.

Contents

Click on a section to jump to it

Introduction	2
Standards and code requirements	2
Data center and EPO requirements	3
Using UPS with EPO	4
How does EPO work?	5
Assuring EPO functionality	6
Recommended practices	6
Conclusion	12
Resources	13

Introduction

Emergency Power Off (EPO) is a safety mechanism intended to power down a single piece of electrical equipment or an entire room of equipment in an emergency, in order to protect personnel and facilities. Some of the situations requiring EPO activation include fire, flood, equipment overheating, and personnel electrocution. The main disconnect device might not be readily accessible during an emergency situation, and EPO provides the means to power down the equipment without having to leave the room or to figure out which switch to operate. In an emergency, a single means to rapidly disconnect power to an entire room might also be preferred over operating multiple disconnect devices, such as might be the case in a complex information technology (IT) environment. Consequently, some safety agencies have mandated a single means of disconnecting power.

EPO can be used either by emergency responders or by equipment operators. Firefighters might use EPO as a quick way to guarantee that emergency responders are not exposed to dangerous voltage, or to eliminate electricity as a source of energy feeding combustion. EPO allows equipment operators to turn off equipment from a safe distance. This is important if equipment is emitting smoke, fire, or fumes, or if another person is being electrocuted.

The EPO system in any data center is a subsystem that facility managers and operations personnel hope to never use. There can be extremely serious consequences associated with abruptly shutting down a data center. The most obvious is lost productivity. On-line transactions can be terminated and possibly lost. Restarting the IT equipment following an abrupt shutdown can sometimes take many hours. There is a high risk of damage to some IT equipment, which might be immediate or it might show up as intermittent failures caused by thermal stress long after power is restored. Replacing lost equipment can take as long as days or months, depending upon the type of equipment and the extent of damage. Some operations require a sequential shut-down to ensure safe operation. Other applications might affect emergency services or other critical control operations. Besides suffering customer dissatisfaction, some businesses might suffer huge economic loss and/or litigation, or even regulatory penalties.

EPO is a subsystem that is specifically designed to override all redundancy and fault tolerance built into the data center physical infrastructure (DCPI), thereby putting the entire network at risk. EPO operation is one of the largest causes of unplanned data center shutdown. The design of an EPO system must therefore try to prevent any possibility of accidental operation, and it must minimize deliberate operation for any reason other than a valid life-threatening emergency.

Standards and code requirements

National regulations and local codes can govern installations. EPO design is affected by both product and installation safety guidelines. Applicable product standards relating to EPO on large uninterruptible power supply (UPS) systems are as follows:

Underwriters Laboratory - UL 1778: A disconnection device shall be provided for the output ac and dc power circuits of a fixed UPS, and for any remote battery supply/cabinet assembly.

EN50091: This European UPS standard requires EPO on any hard-wired UPS. However, the EPO may be integral to the UPS; Activation from EPO stations at exit doors is not mandatory.

Local authorities might require that installed equipment meet the above standards before it can be operated. In addition, local authorities might require that the installation meet some or all of the following requirements:

IEC 364-4-46: This international standard titled: *"Electrical installations of buildings part 4: protection for safety"* requires that a "means shall be provided for emergency switching of any part of an installation where it may be necessary to control the supply to remove unexpected danger." Although not explicitly referenced, computer rooms are considered **to be** such an installation. Furthermore, "the arrangement of the emergency switching shall be such that its operation does not introduce a further danger or interfere with the complete operation necessary to remove the danger."

National Fire Protection Association - NFPA 70®: This US document, also called the National Electrical Code® (NEC®), specifies in clauses 645-10 and 645-11 that UPSs above 750 VA installed within information technology rooms must be provided with "a means to disconnect power to all electronic equipment in the information technology equipment room." This includes all UPS AC and DC supply and output circuits. The disconnecting means shall also disconnect the battery from its load, disconnect the power to all dedicated HVAC systems serving the room, and cause all required fire / smoke dampers to close. Although the terms "emergency power off" or "EPO" are not used in the NEC, this code further requires that the control for these disconnecting means shall be grouped, identified, and readily accessible at principal exit doors. EPO is only mandatory if the room is designated for information technology. The lack of an EPO system disqualifies the room from being classified as an IT space, in which case the room must comply with the standard requirements for building wiring and cabling and disallows some of the leniencies otherwise allowed in Article 645 (such as allowing unsecured cables under a raised floor).

National Fire Protection Association - NFPA 75: This document, titled "Standard for the Protection of Information Technology Equipment", incorporates the related clauses of NFPA 70 and therefore contains identical requirements. It is a standard, not a code, so compliance is therefore not mandatory.

Data center and EPO requirements

One of the most confusing areas for IT professionals is a determination of what constitutes a "data center" and whether an EPO is required. In particular, how big or complex does an installation need to be before it comes under the legal definition of a "data center"? Can a wiring closet be considered a "data center"?

NFPA 70 does not use the term "data center." It describes an "information technology equipment" room as one containing "equipment, power supply wiring, equipment interconnecting wiring, and grounding of information technology equipment and systems, including terminal units." The information technology room per NEC 2005 must meet all of the following conditions in order to qualify for IT room designation.

1. The room is separated from other occupancies by fire-resistant rated walls, floors and ceilings with protected openings.
2. A means is provided to disconnect power to all electronic equipment in the room (EPO). There shall also be a means to disconnect the power to all dedicated heating / ventilating / air-conditioning (HVAC) systems serving the room and cause all fire smoke dampers to close. The control for these disconnecting means shall be grouped and identified and shall be readily available at principal exit doors.
3. A separate HVAC system is dedicated to the room. Any HVAC system that serves other occupancies shall be permitted to also serve the information technology room if fire / smoke dampers are provided at the point of penetration of the room boundary. Such dampers shall operate on activation of smoke detectors and also by operation of the disconnecting means (EPO) for HVAC systems.
4. Properly listed information technology equipment is installed in the room.
5. Only those personnel needed for the maintenance and functional operation of the installed equipment occupy the room.

Based on the above definition, small installations with only a few servers and wiring closets do not typically have all of the above characteristics and are not therefore considered “information technology rooms,” by this code. They might be called “computer rooms,” “data centers,” “network equipment rooms,” or some other designation. However, the owner should seriously weigh the advantages and disadvantages of an EPO. In some cases it might make sense to have an EPO system to protect personnel and equipment from serious injury or damage in case of fire or other emergencies. EPO is desirable for safety, but EPO is undesirable for reliability.

The ultimate decision to require EPO, and how it is accomplished, might be made by the authority having jurisdiction (code inspector). Item (2) above requires disconnection of power to all electronic equipment for an IT Equipment room. Whether or not all power to the room must be disconnected, including incoming power feeders, is subject to interpretation by local authorities. Some inspectors might require that all power feeds to the information technology room be disconnected by the main breakers located outside of the IT equipment room.

EPO might not be required when the nature of the IT equipment’s mission is such that its disruption could decrease safety or increase danger. For example, NEC article 685 says EPO is not required when sequential shutdown is required to ensure safety or prevent serious damage. Telecommunications operations are not required to have EPO when disruption of service would affect safety, such as access to 9-1-1 emergency services. Some exemptions have also been granted by local inspectors when it could be demonstrated that shut-down would have severe financial consequences and that the intent of the code could be met by other safety features and/or practices.

Using UPS with EPO

The NEC and NFPA 75 both state, “A means shall be provided to disconnect power to all electronic equipment. The disconnecting means shall also disconnect the battery from the load.” For a UPS with an integral battery, the NFPA 75 requirement is satisfied by having an EPO that shuts off the UPS output. For a UPS with a remote battery, the battery power must be disconnected by the EPO because a UPS is considered electronic equipment and its dc sources and ac sources must be disconnected. The intent of the code is to prevent a situation in which an emergency responder disconnects power, only to discover that circuits are still energized because they are powered from a UPS system.

If the UPS is inside the data center, then achieving EPO by disconnecting input power to the UPS will not disconnect AC output power, as the UPS will interpret this event as a power failure and simply continue to supply power from its associated battery. Just tripping the UPS output breakers also does not meet EPO requirements, as the UPS itself remains powered even though the loads may be shut down. EPO that trips the UPS input breakers and DC battery breakers would be required. The EPO design should therefore be capable of tripping the breakers feeding main and bypass input power to the data center and DC battery breakers (if battery is not integral to the UPS). It is also required to trip UPS output breakers when the EPO is activated.

NFPA 70 stipulates that the actuation of emergency pushbutton(s) must be accomplished by pushing the button in, rather than pulling it out. As explained in the NEC 2005 Handbook, the requirement recognizes that, “in an emergency situation, the intuitive reaction to operating the control is to push, not to pull, the button.” This language was added to the NEC in response to some remote EPO designs in which a “pull-to-activate” button was used in order to prevent accidental operation. A pushbutton with a cover is the preferred solution.

It is important to distinguish between a “unit EPO” and a “remote EPO (REPO).” The former is located on a piece of equipment. The latter is typically located at exit doors or some other location away from the equipment that it controls. NFPA 70 and other codes generally are

concerned with REPO. A unit EPO function is a common feature in UPSs over 5 kVA and is often available as an option on many smaller units. In some cases, EPO can be retrofitted as a plug-in accessory to a standard UPS. However, the implementation of EPO varies among different UPS. System design work may be needed to integrate the UPS unit EPO with an existing data center remote EPO. Although this is not complicated, it is important to note that integration is usually not a simple plug-in installation. Consult the application or installation notes for the specific UPS.

On larger UPS systems, the primary UPS breakers are contained in a bypass panel, bypass panel / power distribution unit (PDU) or switchgear. The EPO function on larger systems must therefore be able to trip multiple breakers to disconnect all power to and from the UPS.

How does EPO work?

Pressing the remote EPO button instantaneously shuts down all power in the installation. Power cannot be restored at the EPO switch, but must be reset either at the circuit breaker panels or at the load equipment after a determination has been made that it is safe to do so.

In the most basic form, the remote EPO button is wired back to special "remote trip" or "shunt trip" circuit breakers in the UPS system. The special circuit breakers are equipped with "trip coils" which are driven by the EPO circuit. The shunt trip unit consists of a solenoid tripping device mounted in the breaker. The tripping device must be energized by some control power source of AC or DC voltage. When a pilot device, such as a push button, remotely energizes the solenoid coil, the plunger moves to activate the trip bar to trip the breaker. At the same time a cut-off switch operates, disconnecting power to the solenoid and preventing coil burn out. Breakers with shunt trip capability have terminals for connecting the shunt trip control voltage. The shunt trip coils of multiple breakers can be connected in parallel so that a single remote EPO push button can trip many breakers.

There is no code requirement or standard mandating normally-open or normally-closed contacts on the EPO device, although normally-open is most common. Shunt trip breakers trip when the EPO circuit is closed (or opened). Multiple EPO switches can be connected in parallel (or series) to multiple paralleled breakers so that any EPO switch trips all breakers. Care must be taken to ensure that all devices in a circuit operate identically.

Remote trip breakers trip when a control voltage is applied to them. A source of voltage, typically 24 or 48 V AC or DC is required. However, some breakers use 120 V or 240 V AC or dc coils. These can be operated directly from the line. The AC shunt trip control voltage can have a frequency of 50 Hz or 60 Hz. The standards do not specify any particular voltage for shunt trip control in order to allow flexibility in design. Although the shunt trip control voltage can vary in different circuit breakers, the basic operation of the shunt trip unit remains the same.

In contrast to a shunt trip, Undervoltage Release (UVR) is an alternate means available to trip a circuit breaker. As the name implies, the UVR mechanism trips the breaker whenever the control voltage falls below a predetermined level. Like shunt trip units, UVRs are available with a wide variety of control voltage ratings. The UVR consists of a solenoid with a plunger and tripping lever. The UVR mechanism is reset by the tripping lever when normal control voltage has been restored and the circuit breaker handle is moved to the "OFF" position. UVR equipped circuit breakers are frequently used when a normally closed circuit is desired for EPO design. UVR is desirable from a safety perspective because it fails into the open (de-energized) position. However, UVR is undesirable from a reliability perspective because it is vulnerable to nuisance tripping caused by a momentary voltage sag or interruption.

Assuring EPO functionality

From a safety standpoint it is absolutely essential that the EPO works when needed. Two different design approaches can be used: one with normally open (NO) contacts and the other with normally closed (NC) contacts (indicating the respective open or closed position of the contacts when the coil is de-energized). Each of these designs has its own tradeoffs between reliability and safety.

The EPO design with NO contacts uses one normally open contact for each circuit breaker to be tripped. Depressing the EPO pushbutton closes the contact (energizes the circuit) to trip the breaker. Multiple NO contacts are closed by the EPO pushbutton to trip multiple breakers in the information technology equipment room. A broken wire would not be detected by this EPO design. However, a broken wire would not cause a nuisance trip since the contacts are normally open.

The EPO design with NC contacts use one normally closed contact for each breaker to be tripped. The EPO push button in this design will open the contact to trip the breaker. Multiple NC contacts are opened by an EPO pushbutton to trip multiple breakers in the information technology equipment room. If a wire gets broken, it would trigger an EPO event in this type of design. However, if the pair of wires connected to the NC contact is shorted then the connected breaker would not trip in case of an emergency.

Most users demonstrate EPO functionality by periodic tests. In fact, local regulatory authorities may require such tests. It would be highly desirable to have a selection switch on the UPS and ancillary equipment that enables the EPO to be checked periodically by setting the switch to a “test” position. In the “test” position the EPO can be activated and the EPO functionality tested without actually shutting the system down and disconnecting the load. After the EPO test, the switch can be set to its “normal” position

The complexity of the EPO design and associated reliability depends on the size of the installation. A simple EPO push button can be employed for a few pieces of UPS equipment using a set of contacts wired serially to each push button at the exits. This approach works okay for 2-3 circuits, but gets laborious and less reliable for a larger installation. For a data center of multiple UPS components it becomes necessary to design a controller that can trip multiple breakers at the same time. If the controller power supply fails, then the EPO will not function when needed. A UPS can be used to back up the EPO control power supply to increase reliability. However, this increases the complexity of the EPO system and the number of failure modes. In addition, periodic maintenance of the EPO controller would also be required to check the status of UPS battery and other components. An alternative approach would be to design an EPO with passive components that can still reliably trip all associated equipment.

Recommended practices

Data centers or small information technology equipment rooms may have multiple UPS and associated equipment. Since one UPS system may or may not be galvanically isolated from the others, there should be independent contacts for breaker shunt trip or UVR. Whether or not to use a powered EPO device with relays is an important design consideration. If the EPO device has input power, then a UPS would be necessary to make sure that the EPO is ready and functional at all times.

An alternate approach is to use normally open contacts and use an EPO push button that closes multiple independent contacts to initiate EPO function. Such an EPO device would not need any input power. When using multiple EPO devices, it is highly desirable to have pre-made and tested cable harnesses for interconnection that enhances ease of installation and reliability.

EPO devices designed around human factors provide two important benefits:

1. Lower probability of failure due to installation mistakes thus improving the reliability of EPO system operation
2. Lower probability of false trips due to human error, thus increasing the availability of IT operations

The ideal EPO device should be aesthetically pleasing, easy to install and have a large push button. The EPO device should have sufficient room to neatly route and dress wiring connections inside the EPO enclosure. This reduces the likelihood of miswiring by allowing the installer to keep track of all wiring and to see all terminations from one angle. It is also important for the EPO device to be able to trip the main breaker feeding the information technology room. These contacts must be able to accommodate various shunt trip voltages up to 240 V AC.

Figure 1a shows a standard industrial EPO push button device with depths ranging from 6 to 9 inches (15.24 to 22.86 cm). The contacts of the push button are normally stacked in the back making the depth larger as the number of contacts increases. An example of an EPO device with a 2 inch depth (5.08 cm) is shown in **Figure 1b**.

Figure 1a (left)

Standard EPO, 6" - 9" depth

1b (right)

EPO, 2" depth

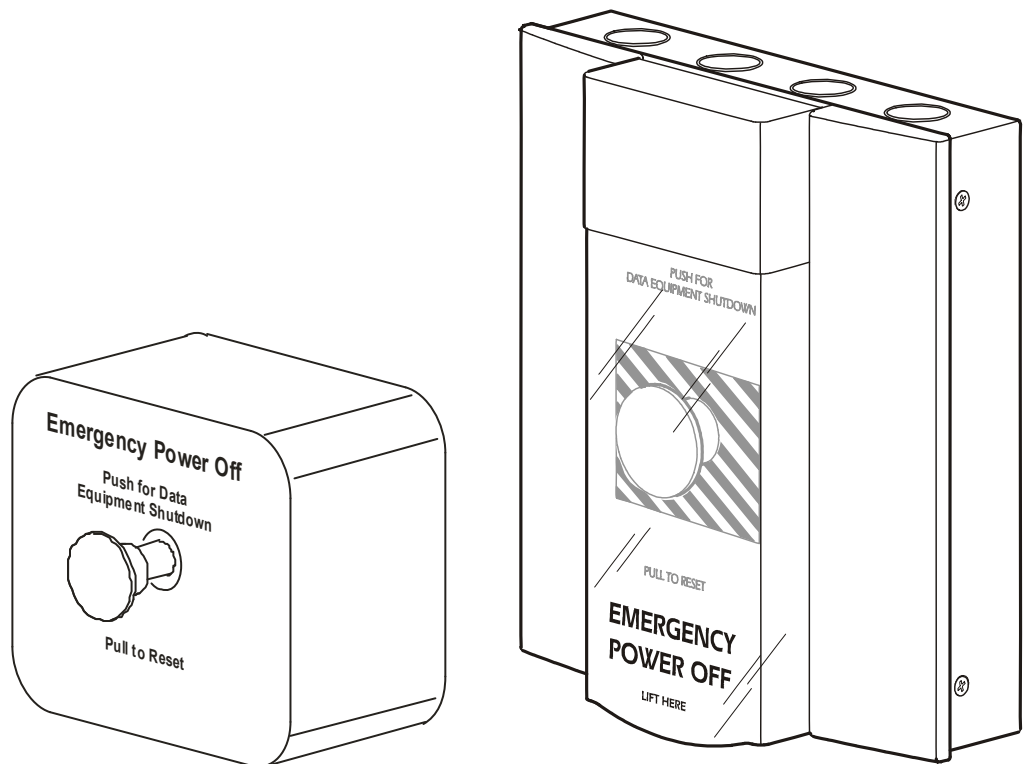

EPO devices should allow for mounting with conduit on the surface of the wall or inside the wall as shown in **Figures 2a and 2b**, respectively.

Figure 2a (left)

Conduit on the wall

2b (right)

Conduit inside the wall

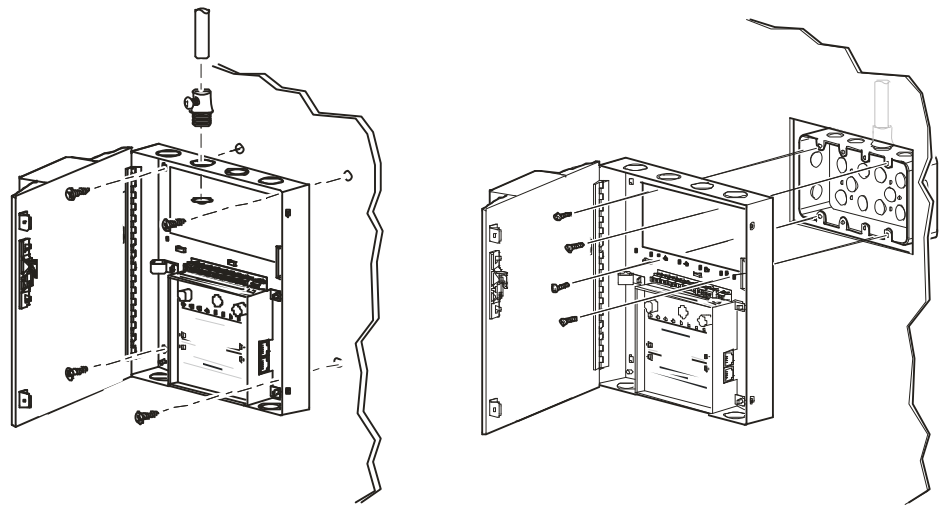

As shown in **Figure 3a**, the wiring inside a standard industrial EPO device typically terminates on the contacts clustered around the push button. The resulting congestion makes it cumbersome to wire and thereby decreases the reliability. EPO devices should allow support for multiple UPS and for tripping one additional circuit breaker (shunt trip up to 240 V AC), which can be the main breaker feeding power to the information technology room. In addition, the wiring inside the device should be intuitive and spacious to allow for organized wire dressing. These features decrease the chance of installation errors and thus increase the reliability of EPO operation. An example of such a device is shown in **Figure 3b**.

Figure 3a (left)

Stacked terminal

3b (right)

Linear terminal block

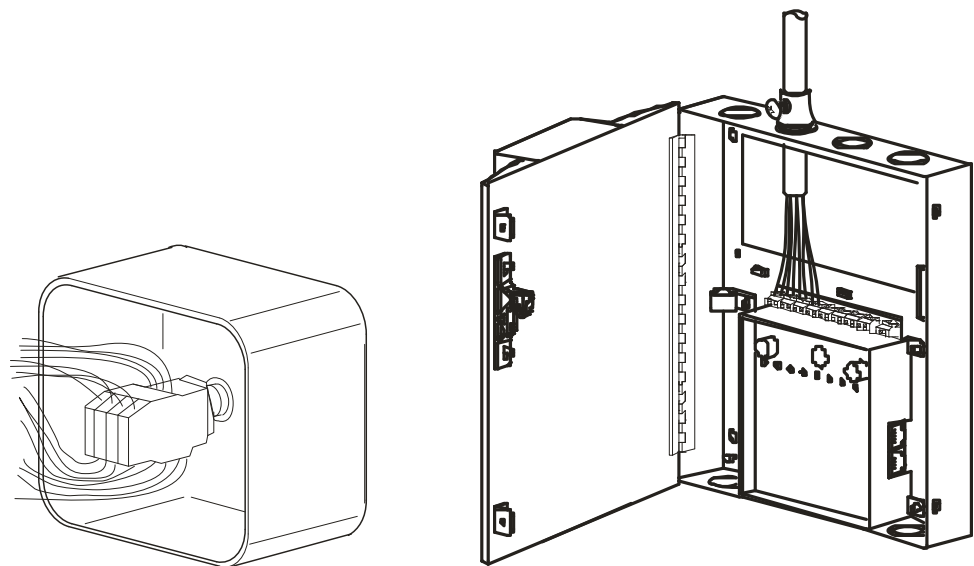

If multiple EPO devices are needed, then the EPO device, like the one shown in **Figure 1a**, will require discrete parallel wires run between individual EPO devices. If an information technology room needs three such EPO devices then the parallel wiring will make this system very messy and unreliable. Alternatively, **Figure 4** shows the parallel connection of EPO devices using pre-assembled CAT-5 cables. The internal connections are done on a printed circuit board. The CAT-5 cables can be obtained with specific lengths required at each location making the installation quick and reliable. Like all EPO connections, the CAT-5 cables should be securely run in conduit to prevent inadvertent disconnection from the EPO device.

Figure 4
Parallel EPO connection
using CAT-5

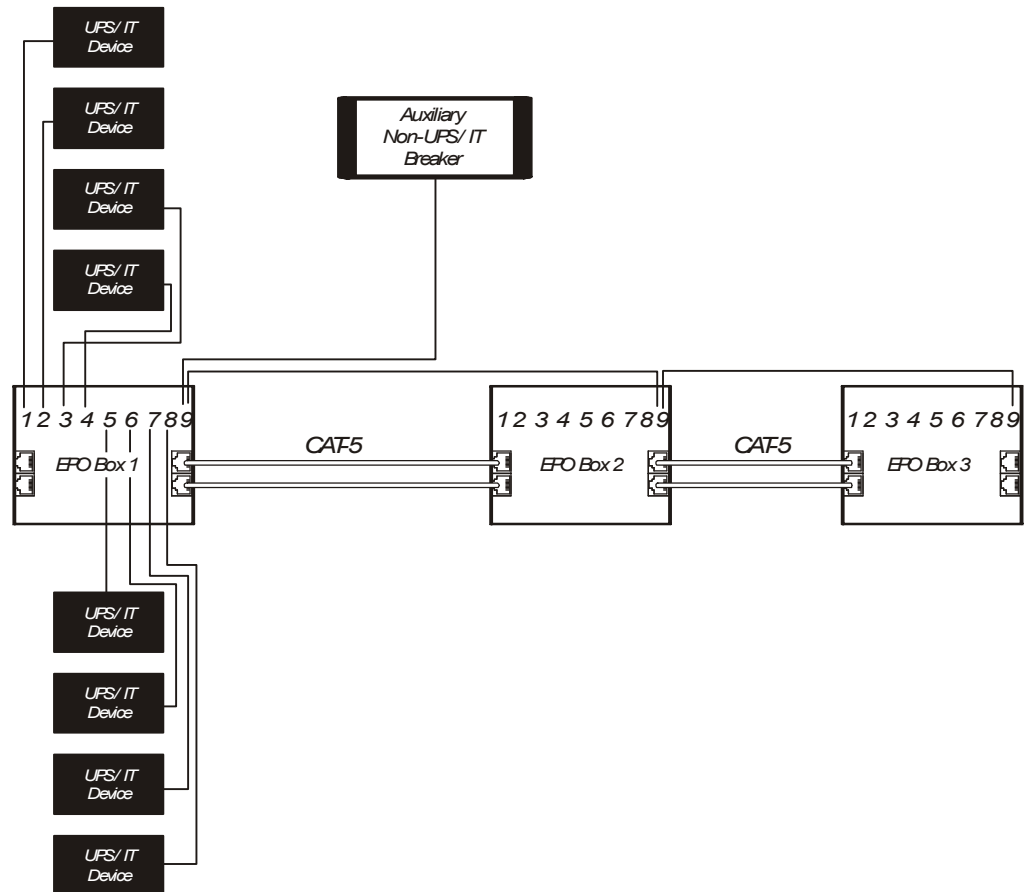

Activation of the EPO pushbutton can instantly shut down the entire information technology equipment room. There is something psychological about a pushbutton located next to a door that tempts some people to push it. Sad but true, EPO operation as a deliberate act of sabotage occurs far more often than we would like to believe. Therefore, the design of the EPO system must prevent accidental closure and discourage non-emergency use or deliberate sabotage, yet it must still allow its operation by a person with a disability. Techniques commonly deployed include:

Pushbutton protection

1. *Guarded pushbutton* - This method recesses the button slightly within a metal tube. It is the least expensive and least effective method.
2. *Covered pushbutton, hinged cover* - This method is the most widely used. It employs a hinged transparent cover that must be lifted to operate the button (see **Figure 1b** or **Figure 6**).
3. *Covered pushbutton, break glass* - This method is psychologically intimidating to the casual button-pusher. It requires the operator to use a small hammer to break a glass window to access the pushbutton. Although psychologically effective, it is expensive to install, difficult to test, and expensive to use (requires replacement of glass), and is therefore not widely deployed.
4. *Lock and key* - This method has the advantage of preventing operation by unauthorized personnel by using a key instead of a button. However, this method has obvious safety disadvantages. For example, it could not be used by a fire fighter, and the process of locating and inserting the key could take up valuable time in a true emergency. Therefore this method is rarely used.

EPO station location

1. A good EPO design will minimize the number of pushbuttons in the same location.
2. The EPO pushbutton station should be clearly separate from any other pushbuttons (for example, on the opposite side of a door).
3. The EPO pushbutton station should be located far enough to the side of a door to prevent its being accidentally bumped or damaged (for example, by equipment being moved through a door).
4. No equipment should obstruct access to the EPO pushbutton or pose a possibility of accidental closure of the pushbutton (such as a copy machine in front of the button).
5. The EPO pushbutton station should not be located where its purpose could possibly be misunderstood (for example, as a door opener).

Signage and security

1. At a minimum, EPO stations should have clearly visible signs: EMERGENCY POWER OFF.
2. Contacts that close when the EPO button is pushed can tie into a management system, thereby creating a record of the exact time and location when the EPO event occurred.
3. An audible alarm / siren and/or a flashing light can be activated when the EPO pushbutton is pressed. Mounting these devices conspicuously above the EPO station sends a psychological message to the operator to only push the button in a true emergency. Some sites add a sign warning “EMERGENCY POWER OFF - Pushing this button will sound a siren.”
4. Cameras - Some sites monitor all doors and EPO stations 24/7 with video cameras. Others add a flash camera and a sign warning, “If you push this button we will take your picture. Push this button only in a true emergency,” in order to dissuade curiosity or sabotage.

It is highly recommended to fully test the EPO system as part of the commissioning phase of a project, and periodically thereafter (e.g., annually). More often than not, EPO controllers are designed to be site-specific and are not fully tested with all the equipment they are supposed to protect because of site testing limitations. It is therefore desirable to have an EPO test function built into the EPO device. An example of an EPO test function is shown in **Figure 5**, in which each individual circuit on the EPO device can be tested by pressing the appropriate micro switches.

Figure 5
EPO test function

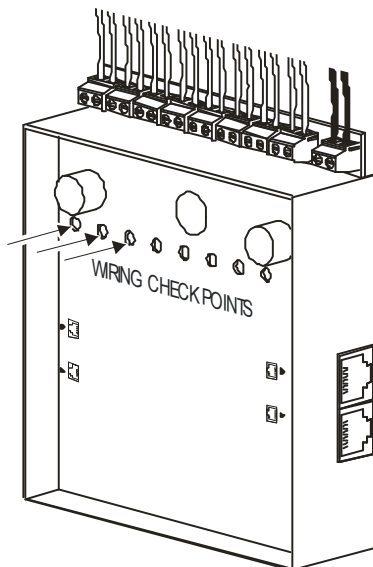

Another desirable feature in an EPO device is a record of which device was activated for accident investigation. On a sophisticated “active” microcontroller-based EPO device, this is accomplished by communication to the Building Management System. On a “passive” EPO device that does not have any input power and microcontroller, two features are available for indication when the device is activated. First, the EPO push button is a latching type which provides one indication of activation of the device. Secondly, the EPO device has a red flag that drops down as soon as the protective cover over the push button is lifted up for EPO activation as shown in the **Figure 6**.

Figure 6
EPO activation

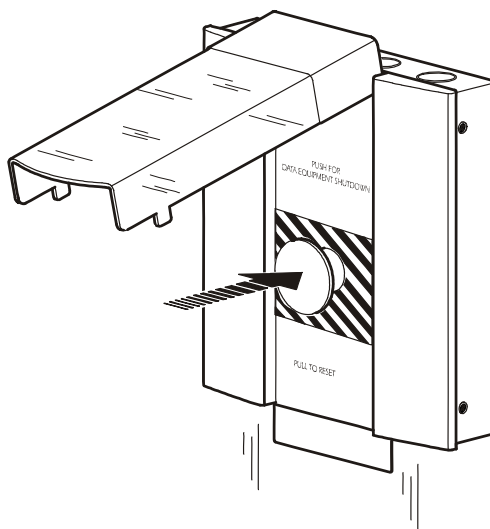

Conclusion

EPO is an important safety mechanism for UPS equipment within a data center, but it also poses a great risk to the reliability of the information technology equipment. Emergency Power Off stations might be required by code in some jurisdictions and in some applications. This paper discusses various codes and standards that require the use of an EPO device. In addition, careful attention must be paid to design features of the EPO device such as size, type of contacts, wiring neatness, complexity, cost, security, etc. The EPO device must also be fully tested with the information technology facility that it protects. Following recommended practices for an EPO device will increase reliability and reduce human error.



About the author

Stephen McCluer is a Senior Applications Engineer for external codes and standards compliance at APC by Schneider Electric. He has 25 years of experience in the power protection industry, and is a member of NFPA, ICC, IAEI, ASHRAE and the IEEE Standards Council. He serves on a number of committees with those organizations, is a frequent speaker at industry conferences, and has authored technical papers and articles on power quality topics.



Resources

Click on icon to link to resource



APC White Paper Library
whitepapers.apc.com



APC TradeOff Tools™
tools.apc.com



Contact us

For feedback and comments about the content of this white paper:

Data Center Science Center, APC by Schneider Electric
DCSC@Schneider-Electric.com

If you are a customer and have questions specific to your data center project:

Contact your **APC by Schneider Electric** representative