

Rack Powering Options for High Density in 230 V AC Countries

White Paper 28

Revision 1

by Neil Rasmussen

> Executive summary

Alternatives for providing electrical power to high density racks in data centers and network rooms are explained and compared. Issues addressed include quantity of feeds, single-phase vs. three-phase, number and location of circuit breakers, overload, selection of connector types, selection of voltage, redundancy, and loss of redundancy. The need for the rack power system to adapt to changing requirements is identified and quantified. Guidelines are defined for rack power systems that can reliably deliver power to high density loads while adapting to changing needs.

Contents

Click on a section to jump to it

Introduction	2
Historic means for providing rack power	2
Rack powering requirements	2
Selecting the appropriate power distribution system	10
Adaptable power architecture for rack enclosures	14
Conclusion	16
Resources	17
Appendix	18

Introduction

Information Technology (IT) refreshes in the data center and network room typically occur every 2 to 3 years. As equipment is changed, the power requirement, the redundancy requirement, and the connector requirement often change as well. As rack enclosures have become the standard means for housing and organizing computing and communication systems, the power distribution system for the rack enclosure must adapt to these changing requirements.

Power density predictions for racks in data centers have sharply escalated as a result of the high power density of the latest generations of computing equipment. Off-the-shelf IT equipment such as 1U servers or blade servers can draw 20 kW or more in a fully configured rack. This density cannot be supported in a data center environment where the average rack is fed by a single 230 V 10A power circuit. Twenty of these circuits would be required per-rack to support a 20 kW load in a dual-path electrical environment.

The power requirements of modern computing equipment vary as a function of time depending on the computational load. Until the year 2000, this variation was very small and could be ignored for almost all computing and communication systems. However, the implementation of power management technologies into processors and servers began during the year 2000; today the fraction of computing equipment which has a substantial variation in power consumption in response to the computing load is increasing. This variation can be as high as 200% of the baseline power consumption of the equipment. The power distribution system design for a rack enclosure must comprehend this variation.

This paper is focused on AC rack power distribution. DC power distribution has a very limited role in the modern high density data center, as explained in APC White Paper 63, *AC vs. DC for Data Centers and Network Rooms*.

This paper is limited to a discussion of 230 Volt distribution systems and connector standards. The appropriate rack power distribution strategy is considerably different for 120 Volt distribution systems, which predominate in North America.

 Related resource
APC White Paper 63
AC vs. DC for Data Centers and Network Rooms

Historic means for providing rack power

The most common approach today is to design, engineer, and install power solutions specific to a rack enclosure. Should the requirements for that rack enclosure change, an alternative power solution must be designed, engineered, and installed. While this approach can comprehend any unique power requirement, it involves significant planning, engineering, and rewiring. Rack enclosures are usually fed from a common power distribution panel within the data center or network room. In many instances, this panel cannot be de-energized in order to adapt a rack enclosure(s) power distribution system (i.e. install another circuit breaker). The result is known as “hot work” and not only introduces a very serious safety hazard, but a high degree of risk of creating a fault in the circuit being worked on and / or dislodging / faulting adjacent wiring circuits. Such errors result in undesirable downtime.

Ideally, the rack enclosure power system would be adaptable to any realistically possible combination of equipment, on demand, without the need to perform any work that would be a hazard to safety or that might adversely affect system availability.

The various dimensions of rack enclosure power requirements are summarized in the following sections. The nature of the requirements is outlined and rational design approaches are summarized.

Rack powering requirements

Voltage requirements

In the majority of the world, data centers are provided with 230 V power. This makes power distribution rather simple compared to data centers in North America. The selection of 230 V as a single voltage standard for a data center assures compatibility with over 97% of equipment, including the most critical equipment. For some equipment it is necessary to switch the power supply from 120 V to 230 V operation with a selector switch; the failure to activate this switch on equipment so-equipped can lead to catastrophic failure when powered by 230 V. The 3% of equipment that only operates from 120 V can be excluded from the data center, because in almost all cases these devices are small accessory equipment that has acceptable and readily available substitutes that will operate on 230 V.

The rack environment is single-phase. There is an insignificant quantity of rack mounted IT equipment manufactured that requires three-phase power (Some brands of blade servers being notable examples). Occasionally, a pre-configured OEM rack enclosure is wired using an internal power distribution unit (PDU) that takes in three-phase power and provides three branches of single-phase power to the single-phase IT loads. It is important to note that these IT loads are actually single-phase. Despite the absence of three-phase loads, there is a good case to be made that three-phase power should be distributed to racks as will be shown later in this paper.

Power requirements

Power densities within the rack enclosure can vary greatly depending upon the equipment installed. In the extreme low load case, a rack enclosure may only have passive patch panels or a few internetworking switches with a power draw of <100 W. In the extreme high load case, a rack enclosure may be completely filled with high-density servers for a total load of 20 kW or more.

In addition to supplying the total rack power requirement, the rack power system must also be able to provide the required power to an individual device. Sending multiple branch circuits to a rack may appear to provide the total power requirement, but the power requirement of an individual large load may exceed the capability of any of the branches. For example, sending any number of 10A branch circuits to a rack where a single piece of equipment requires 16A is insufficient. Another example is a blade chassis with a 16A connector that may be initially populated with only a few blades and use 5A on a 16A circuit. Some customers may think they can put multiple blade chassis' on a single 16A circuit, but as they populate the chassis they overload the circuit. In cases like these, it is recommended that only one load device be attached to each branch circuit.

The appropriate design value for average rack power level is a subject of considerable controversy. An APC by Schneider Electric survey of usage patterns in corporate data centers, network rooms, and communication rooms for the year 2004 identified the distribution of per-rack power consumption shown in **Figure 1**. This graph shows the frequency of occurrence of racks configured to different power levels. The frequency of occurrence goes down with increasing power level. 95% of racks draw power below 6.5 kW.

A projection of usage in the year 2008 (based on technology / client trends) is also shown in **Figure 1**. This indicates that the average power per rack is increasing over time. It is possible to configure IT equipment today that would exceed a 20 kW per-rack power requirement if fully populated into a rack enclosure. While possible to achieve, we did not find this occurrence to be frequent in real-world installations. The data collected indicates that the average power density per rack enclosure will rise significantly. However, power densities >6 kW will still remain a small fraction of the installed base.

Figure 1

Per-rack power consumption frequency distribution

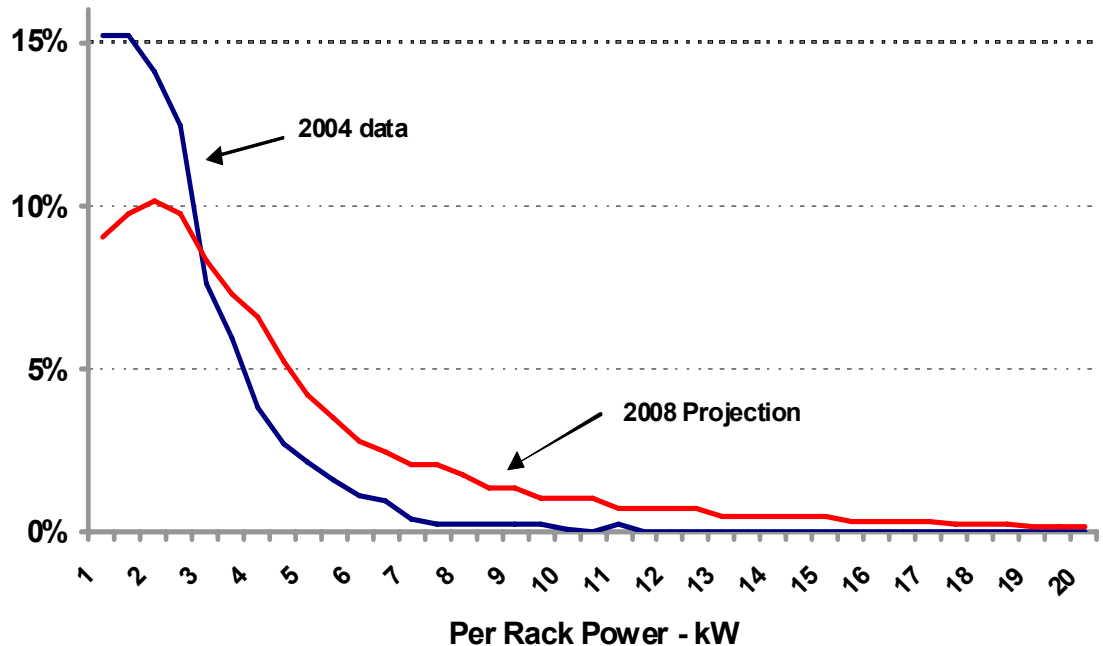

An analysis of the underlying data of the distribution of rack power indicates the following:

- The very low loads are mainly rack enclosures with wiring patch panels, switches, and hubs
- Loads in the 1 kW range are mainly sparsely populated rack enclosures
- Loads in the 2-3 kW range are mainly rack enclosures that are populated with typical equipment but with significant unfilled rack space
- Loads in the 5 kW range are partially loaded with 1U servers, or contain a mix of technologies
- Loads in the 7 kW + range are rare but, according to customers, are going to become more common with the recent density increases resulting from server technology advancements

The mean value for rack power consumption in corporate computing environments is around 1.7 kW. However, organizations were found to have variable mean power consumption within their overall rack enclosure environment. These organizations take different approaches as to how much equipment they pack into a rack enclosure. Some leave large amounts of space within the rack enclosure unused while others may pack equipment as tightly as possible. Therefore, the market-wide mean rack power consumption is not necessarily a good predictor of average rack power consumption within an organization.

The electrical circuits between the last over-current protector and the equipment are called "branch circuits". In most 230 V countries, virtually all branch circuits in rack enclosures are rated for 16A¹.

¹ Note that 25A and 32A circuits are also sent to the rack but these circuits are feeder circuits and not branch circuits, because they require additional circuit breakers in the rack as described in later sections. Very few rack devices can directly utilize a 25A or 32A branch circuit; these are usually blades, routers or free-standing servers or storage devices.

Table 1

Branch circuit power limitations

Voltage	Max branch current rating	Maximum kW capacity per branch	Total rack power for 1/2/3/4 branch circuits
230 V	16A	3.7 kW	3.7 / 7.4 / 11 / 14.7

The maximum power available to the rack enclosure depends on the number and type of branch circuits provided within the rack enclosure. Clearly the number of branch circuits will need to be greater than one to support the power density of current and future IT technology.

Combining the data from **Table 1** and data from **Figure 2**, the following conclusions can be drawn:

- A single 230 V branch circuit can supply the load requirement for the most common rack enclosures today, but this will not be true in the future.
- Two 230 V branch circuits can supply the load requirement for approximately 98% of rack enclosures today, but only 90% of racks in the future.
- Three 230 V branch circuits in can supply the load requirement for nearly all of rack enclosures today, and still over 98% in the future.

Note that the inability to provide sufficient branch circuits to a rack enclosure does not prevent operation of the system. If the rack has insufficient power distribution capacity, the power drawn by a rack enclosure can be reduced by removing equipment from it and moving it to another rack enclosure. However, the consequence is that a reduction in space utilization occurs. For an occasional rack enclosure this is not a serious problem. The costs and benefits of spreading loads within the data center are discussed in APC White Paper 46, *Cooling Strategies for Ultra-High Density Racks and Blade Servers*.

An adaptable rack enclosure power system would be able to provide enough power to supply the maximum anticipated load to any rack enclosure at any time without re-engineering the power system. Two 230 V branch circuits per rack enclosure is a practical design baseline, with the ability to add additional circuits easily as needed.

Redundancy requirements

Providing redundancy and / or fault tolerance in the power system can increase the availability of a computing system. In high availability environments, a common way to provide redundancy is to supply two independent power paths to each piece of computing equipment; the equipment in turn accepts the two power feeds via independent paralleled power supplies that are sized such that the equipment will continue to operate with only one power path.

This system provides the following key advantages:

- If a power supply fails the system continues to operate
- If one power feed fails due to equipment malfunction the system continues to operate
- If one power feed fails due to user error the system continues to operate
- If the power supply fails in a way which faults the power feed and trips breakers, the equipment sharing the breaker is not affected.
- If one power feed needs to be shut down for maintenance or upgrade, the system continues to operate

For this approach to be effective, the following requirements must be met:

 Related resource
APC White Paper 46
Cooling Strategies for Ultra-High Density Racks and Blade Servers

1. The protected equipment must support dual power feeds and operate with one feed faulted
2. The loading of breakers within each power path must always be less than 50% of trip rating during normal conditions, so that the increase in load that will accompany failure of the alternate path does not cause breakers to trip. This also helps prevent tripping of the alternate path due to low line voltage conditions.

Meeting these two requirements can be very difficult. Some computing equipment is only available with a single power cord. There is also equipment manufactured with three power cords, where any two are needed for proper operation. These types of equipment cannot operate with the loss of one power feed. In these cases an Automatic Transfer Switch (ATS) can be used which generates a single feed from two inputs. Such an ATS may be deployed centrally or it may be deployed in a distributed manner by placing small rack mount ATS in the rack enclosure with the protected equipment. For more information see APC White Paper 48, *Comparing Availability of Various Rack Power Redundancy Configurations*.



Related resource
APC White Paper 48

*Comparing Availability of
Various Rack Power
Redundancy Configurations*

An adaptable rack enclosure power system would be able to support a single or dual path environment or a hybrid of both single and dual equipment. In addition, it is necessary to provide current monitoring to ensure that all circuits are loaded below 50% capacity in order to prevent breaker tripping during a loss of one power path.

Overload protection requirements

One of the most misunderstood concepts of power distribution is the over-current protection of branch circuits. Each branch circuit in a rack enclosure must be supplied by an independent circuit breaker and a typical rack enclosure will need multiple branch circuits. **Figure 2** illustrates the common methods of power distribution to the rack, showing different branch circuit configurations. In **Figure 2a**, a single branch circuit supplies a rack. For a 10 Amp system, this arrangement is limited to 2.3 kW max capacity at 230 V. To achieve higher rack power, a larger breaker and conductor are required or multiple branch circuits are required. There are two options for providing multiple branch circuits to a rack enclosure, and these are shown in **Figure 2b** and **3c**.

Figure 2

*Illustration of methods
of delivering branch circuits
to the rack, showing alternate
ways of supplying multiple
branch circuits to a rack*

2a.

Single branch circuit to the rack

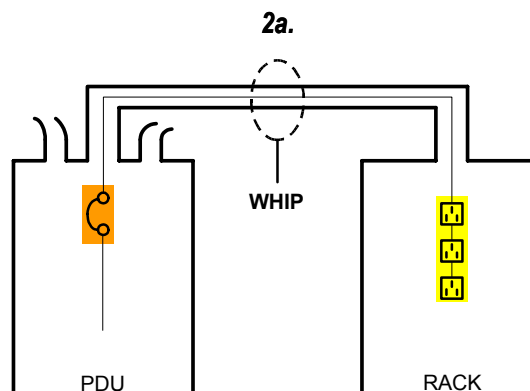

2b.

Multiple branches: generate required branch circuits at the PDU

2c.

Multiple branches: generate required branch circuits within the rack

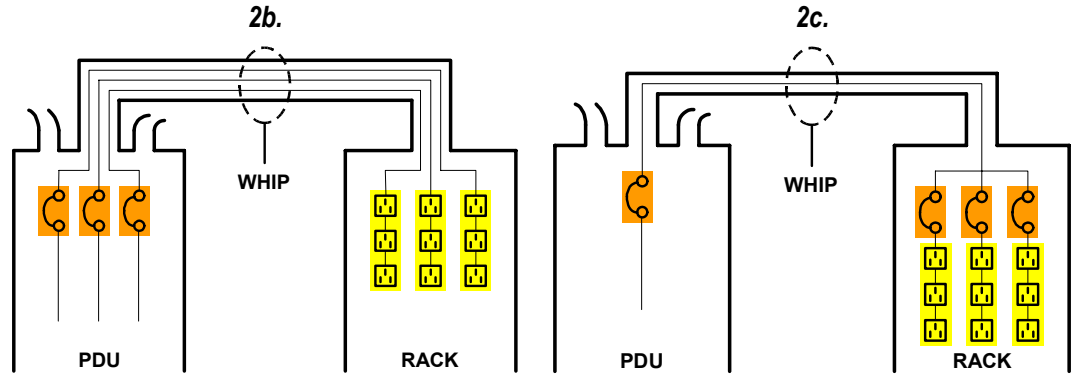

The arrangements of **Figure 2b** and **2c** are capable of providing the same power, but with a different wiring and circuit breaker arrangement. Note that in **Figure 2b** the conduit or “whip” contains multiple branch circuits. These alternatives give rise to significant advantages and disadvantages as summarized in **Table 2**.

Table 2

Comparison of the two options for providing multiple branch circuits to a rack enclosure

	Number of feeds	Location of breakers	Advantages	Disadvantages
Generate required branch circuits at the PDU	One feed per required branch circuit	PDU only	Fewer total breakers No fault coordination issues Each branch usable to full capacity Feed to rack may be pluggable	More circuit breaker positions required in the PDU
Generate required branch circuits within the rack enclosure	Fewer feeds per voltage required within the rack enclosure	Feed breakers in PDU Branch breakers located within rack enclosure	Fewer feeds to rack Fewer breakers in the PDU	More breakers to monitor for overload. Fault coordination. Branches may not be usable to full capacity. More breakers in series reduces reliability Feed may need to be hardwired. Small electrical efficiency penalty due to losses in extra breaker(s)

The summary of **Table 2** suggests there is a significant advantage to avoiding the need to generate branch circuits in the rack enclosure.

Most users who send 25A or larger circuits to racks do not understand that these circuits are feeder circuits and **not** branch circuits. When 25A (or greater) whips are used, the typical 16A branch circuits required to supply receptacles **must** be provided by branch-rated breakers located **within the racks**.

An adaptable rack power system would eliminate the need for hard wiring, cascaded breakers, and breaker coordination analysis, which would suggest a preferred approach of multiple branch circuits per rack. Ideally, multiple branches would be provided using a single multi-conductor cable to the rack in order to simplify wiring to the rack.

Connector requirements

Over 99.99% of all AC powered equipment used in rack enclosures are connected via a power cord and plug (a negligible fraction is hard-wired). Furthermore, 99% of all IT equipment in the data center utilizes a detachable power cord which means that the plug type can be changed. OEM suppliers take advantage of this when creating complete rack systems and often will install cords with IEC 60320 (previously IEC-320) style power plugs on all the equipment in the rack enclosure, along with an IEC60320 style outlet strip. This has the benefit that a single configuration can be used worldwide. Internationally, the approximate statistical breakdown of frequency of occurrence for IEC plug types is provided in **Table 3**:

Table 3

Frequency of occurrence of IEC connector types on IT equipment

Frequency	Connector type	Description	Where used
80%	IEC 60320 (previously IEC-320) C-14 (Male) C-13 (Female)	230 V 10A (single phase)	Small servers, hubs, departmental switches, monitors, power blocks, enterprise servers, routers, some blade servers, large departmental servers
16%	IEC 60320 (previously IEC-320) C-20 (Male) C-19 (Female)	230 V 16A (single phase)	Enterprise servers, routers, some blade servers, large departmental servers, storage equipment
1%	IEC 60309 (previously IEC-309)	230 V various current ratings (single and 3Phase)	Enterprise servers, carrier class routers, storage equipment
3%	Other IEC	230 V various current ratings (single phase)	Small servers, hubs, departmental switches, monitors, power blocks

Plugs do vary by country, but unlike North America, most countries use a single service voltage and therefore most power cords are rated for 230 V 16A. This means that a single plug type serves most applications from small hubs to enterprise servers. Unfortunately, instead of using IEC plugs to power their equipment, many IT personnel use country specific plugs (i.e. Shuko or UK) and forego all the advantages of standardization. Reasons for this include the fact that some equipment suppliers don't include power cords with IEC to IEC connectors on both ends. Even when these IEC cords are included, oftentimes they are discarded and the country specific cord is used instead. In fact the benefits of standardization are so poorly understood that when only IEC to IEC cords are supplied, some IT personnel request country specific cords from the supplier.

By standardizing on IEC plug types, PDUs and UPSs, IT managers facilitate IT refreshes by having a predictable power scheme where nearly all rack mount equipment is powered from either a C13 or C19 receptacle. This benefit becomes even more valuable when multiple data centers are managed across various countries. For example, the procurement of country-specific PDUs creates the need to source from various vendors which adds further complexity to data center management. Lead times for PDUs with unique receptacle

 Related resource
APC White Paper 116

Standardization and Modularity in Data Center Physical Infrastructure

combinations cause schedule and cost overruns. The various combinations of plug types quickly become overwhelming from an inventory and management perspective. For more information on the benefits of standardization see APC White Paper 116, *Standardization and Modularity in Data Center Physical Infrastructure*.

The number of receptacles required in a rack enclosure varies dramatically with the installed equipment. A rack enclosure may contain only a single load as a minimum. Conversely it may be populated with (42) thin servers with dual power cords for a total requirement of 84 receptacles.

An adaptable rack enclosure power system would be able to provide power receptacles for all the various plug types, which might be encountered, as well as two feeds, each containing (42). To accomplish this, one must provide a large quantity and assortment of receptacles in every rack enclosure, or provide a number of easily changeable outlet strip options to meet evolving requirements.

Harmonic requirements

Historically, computing equipment generated harmonic currents on AC power lines, which led to the need to incorporate specialized features into power systems such as oversized neutral wiring and K-rated transformers. During the 1990's, regulations placed on the design of computing equipment, combined with the gradual retirement of older equipment, resulted in the elimination of this as a problem by the year 2000. Harmonic-rated wiring and transformers are not needed in the rack enclosure power environment. See APC White Paper 26, *Hazards of Harmonics and Neutral Overloads* for more information on this subject.

 Related resource
APC White Paper 26

Hazards of Harmonics and Neutral Overloads

De-rating requirements

Unlike North America, international circuits do not required de-rating. Therefore the user can expect to utilize the full current or power rating of the system. The power capacities of the distribution architectures described in this paper are full rated values.

Cabling requirements

Cables to deliver power to the rack enclosures are an essential part of the rack enclosure power system. A common practice today is to use under floor power cabling. The under floor power cabling method presents a number of barriers to adaptability, which are described in APC White Paper 19, *Re-examining the Suitability of the Raised Floor for Data Center Applications*.

In an adaptable rack enclosure power system, the cabling provided to each rack would provide all the branch circuits that might ever be required. No changes to the cabling would be required due to equipment changes in the rack enclosure. It would also be easy and safe to provide the appropriate power feeds to additional rack enclosures in the future.

Current monitoring requirements

Rack enclosure power systems are subject to constant load changes due to the installation and removal of equipment and to the dynamic power draw variation in the installed equipment. These circumstances lead to a requirement to monitor power flowing in branch circuits in order to prevent failures or hazard due to overloads. This subject is described in detail in APC White Paper 43, *Dynamic Power Variations in Data Centers and Network Rooms*.

 Related resource
APC White Paper 19

Re-examining the Suitability of the Raised Floor for Data Center Applications

 Related resource
APC White Paper 43

Dynamic Power Variations in Data Centers and Network Rooms

Consistency requirements

Due to the large number of power circuits in the typical data center, there is a significant advantage to minimizing the different types of power distribution provided (branch circuit ratings, poles per whip, circuit breaker types and location, etc). Ideally a uniform single type of power feed would be provided to every rack to maximize flexibility and reduce human error.

Human error is a constant threat in a data center and has been the cause of much downtime. Standardizing on a common power distribution circuit that fulfills the need 97% of the time is just one method of reducing the risk of human error. With standardized whips users are less apt to become confused, parts are minimized and learning curves are accelerated all which lower the risk of a costly mistake.

Selecting the appropriate power distribution system

Despite the number of requirements, there remain various combinations of circuits that can be used to power rack enclosures, each providing different total power capacity and differing in key features. There are at least 22 practical but different ways to provide power to rack enclosures in the range of 2.3 kW to 44 kW per rack. The details of these alternatives are provided in **Appendix A**.

Through a systematic investigation of these alternatives, it is possible to determine that these alternatives are not equivalent in their costs and benefits, and that some options are clearly preferred. The analysis of **Appendix A**, when considered with the requirements defined in the previous section, suggests that there are four essential preferred forms of rack power distribution between the PDUs and the racks, which are used in multiples per rack to achieve a desired power density. The four preferred forms are:

- 230 V 16A whips**
- 230 V 32A whips**
- 230 V/400 V 16A 3-phase whips**
- 230 V/400 V 32A 3-phase whips**

Figure 3 illustrates these four preferred forms by showing the branch circuit configurations. The characteristics and advantages of these four essential preferred types of power distribution are provided in **Table 4**. In **Table 4**, the shaded attributes represent the best performance for that characteristic. The figure shows the clear advantage of 3-phase distribution to the rack.

The analysis of this paper suggests that distribution whips that include single or 3-phase 25A whips are not preferred except in the case of dedicated whips. The 25A whip value is not optimal because the most common branch circuit size that must be generated in a rack is 16A, which leads to two undesirable problems with a 25A whip size:

1. The coordination between a 16A branch circuit breaker and a 25A feeder breaker is difficult to achieve increasing the likelihood of cascade breaker tripping.
2. Two 16A branches are required to fully utilize a single 25A whip phase feed, and if one of these branches is fully utilized the other can only be halfway utilized. This is an inefficient use of circuit breakers; furthermore, the feeder breaker may trip before the branch breakers trip.

When a density higher than that provided by one or more 16A or 16A 3-phase whips is required, a 32A 3-phase whip is the preferred solution over a 25A 3-phase whip.

Figure 3

Illustration of the four preferred forms of power distribution to the rack

3a.

230 V 16A whip

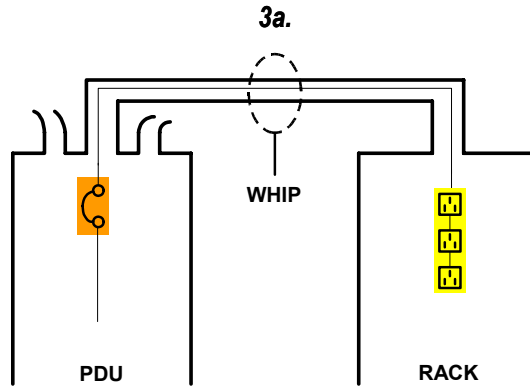

3b.

3b.

230 V 32A whip

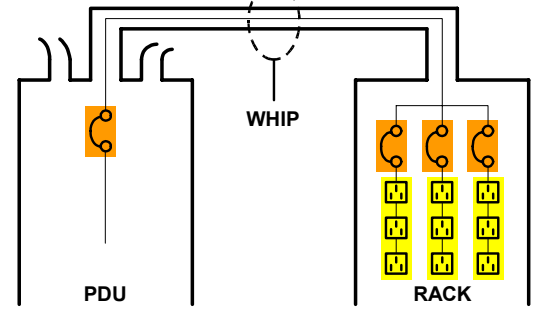

3c.

230 V 16A 3-phase whip

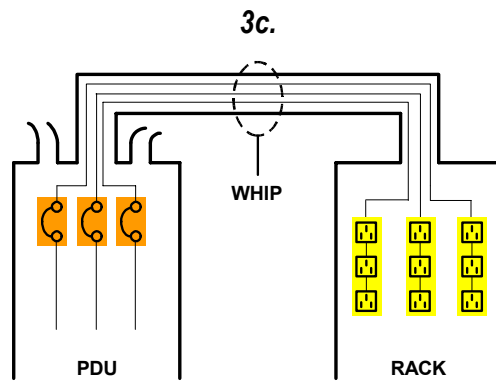

3d.

3d.

230 V 25A 3-phase whip

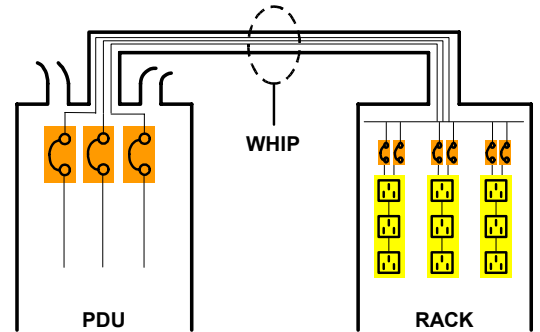

Table 4

Characteristics of the four preferred types of rack power distribution

Characteristic	230 V 16A	230 V 32A	230/400 V 16A 3-phase	230/400 V 32A 3-phase	Comment
kW levels obtainable from 1, 2, 3 or 4 whips	3.7 7.4 11 14.7	7.4 14.7 22.1 29.4	11 22.1 33.1 44.2	22.1 44.2 66.2 88.3	
kW per whip	3.7	7.4	11	22.1	
kW per PDU breaker panel pole position	3.7	7.4	3.7	7.4	
Max single load kW	3.7	7.4	3.7	7.4	There are currently almost no production IT rack products that require over 7.4 kW per plug, but this could change.
# of 1 kW IT devices per whip	3	7	11	22	Note that a dedicated feed only supports a single device.
# of breakers in series with load	1	2	1	2	
Fault coordination	E	G	E	G	32A designs require additional branch breakers in the rack.
Cost per kW @ 2 kW per rack	\$270	\$320	\$515	\$645	Includes source breaker, whip, and rack PDU.
Cost per kW @ 10 kW per rack	\$81	\$64	\$52	\$64	Includes source breaker, whip, and rack PDU.

Note: Shading indicates best performance for the characteristic
 Note: whip costs do not include any installation costs
 Fault coordination – legend: E = excellent G = good P = poor

The preferred forms may be used in multiples to achieve higher total rack power ratings. **Figure 4** shows the number of whips required to achieve increasing total rack power ratings. The four curves on the chart represent the whip count for various types of power distribution. The 230 V 25A 3-phase rack power distribution circuit is not a preferred approach but is in the chart for reference. Note that the number of whips required increased linearly with rack power rating as expected. For power ratings greater than 11 kW per rack the number of whips becomes large for the 230 V 16A and 32A single phase systems.

Note that for 2N dual power path systems the number of whips in **Figure 4** must be multiplied by 2.

Figure 4

Number of rack power whips or feeds required as a function of the rack power rating

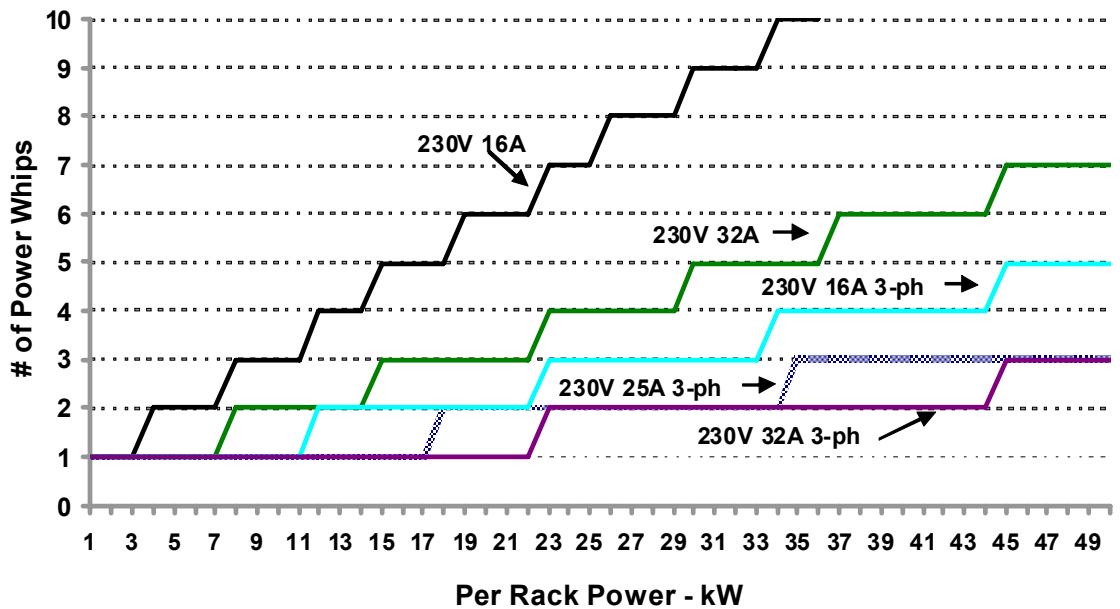

Dedicated whips

Another form of power distribution is dedicated whips. However, dedicated whips are preferred only when the load equipment in a rack has a small number of power cords that each draw a large amount of power, particularly if the equipment uses an unusual plug type or power configuration. In fact, a recognized trend of compacting IT equipment is leading to two important consequences:

- Increased current and power drawn by each equipment power cord is approaching its 16A limit. As a result, multi-outlet rack-based power strips are reduced to one usable outlet per phase.
- Increased data cabling in the back of the rack leaves less room for rack-based power strips

These consequences are forcing IT operations personnel to forego traditional rack-based power strips in high density applications. Instead, they are utilizing dedicated three-phase whips which free up space for data cabling. Certain blade servers and SAN storage units are candidates for this approach. For example, a large blade server power subsystem that has a 3-phase IEC 60309 power plug.

The advantage of dedicated whips is that they never require an additional circuit breaker in the rack, increasing reliability and saving expense. The big disadvantage of dedicated whips is the lack of flexibility when equipment is changed in the future. Dedicated whips are compared to standard 230 V 32A whips in **Table 5**.

Table 5

Comparison of the two options for providing very high density power

	Number of whips	Method of change	Advantages	Disadvantages
Standard 230 V 32A 3-phase whips	One whip per every 22 kW	Easy: Plug in different outlet strips in the rack	Various outlets provided for small or unplanned equipment	Limited to 22 kW
Dedicated whips	One whip per power cord in the rack or one three-phase whip for every three power cords in the rack	Difficult: Power down and run new wires to the PDU	No fault coordination issues No risk of tripping breaker given 1 to 1 relationship between power cord and breaker Can handle any strange plug or circuit size Lowest cost	Must plan in advance and know every power cord that might exist in the rack No provision for small ancillary IT equipment Feed must be hardwired.

In general, dedicated whips should only be used when the power requirement or plug configuration cannot be provided by a standard IEC 230 V 32A 3-phase circuit, or when cost is much more important than the ability to reconfigure the rack later.

Distribution selection strategy

From this analysis it is possible to draw conclusions regarding a preferred arrangement for branch circuits, which is as follows:

1. Use a single 230 V 16A single phase power whip to supply common medium density racks up to approximately 4 kW / rack; supply this by default to every rack.
2. Use a single 230 V 16A 3-phase whip to supply higher density racks up to approximately 11 kW per rack
3. For densely packed 1U server or blade server applications, use either one or two 230 V 16A 3-phase whip.
4. For certain extremely high density loads that have input current requirements per power cord of over 20A, use two or more 230 V 32A 3-phase whips.

Adaptable power architecture for rack enclosures

The growing recognition of the issues described in this paper have led data center and network room designers and operators to develop their own ingenious solutions to address the need for adaptable rack enclosure power systems. Nevertheless, an integrated and cost-effective approach from the point of view of the equipment providers has been lacking. A fully integrated approach would include a modular system that implements all aspects of power distribution from the AC mains connection of the facility, through the UPS, through the power panels, all the way down to the mechanics of connection of the plugs in the rack enclosures.

The first integrated and adaptable rack enclosure power system was introduced in 2001 and is shown in **Figure 5**. The patent-pending InfraStruXure™ system includes components that are engineered to meet the requirements of an adaptable rack enclosure power system. The

system includes prefabricated multi-branch power distribution whips, Quick-change multi-voltage metered outlet strips with various receptacle configurations, pre-engineered circuit breaker coordination, single and dual-path power feed support configurable at the rack enclosure or row level, point of use DC capability, and rapid conduit-free installation. This system is provided as an integrated system that can be configured to order from stock components.

Figure 5

An example of an adaptable rack power system

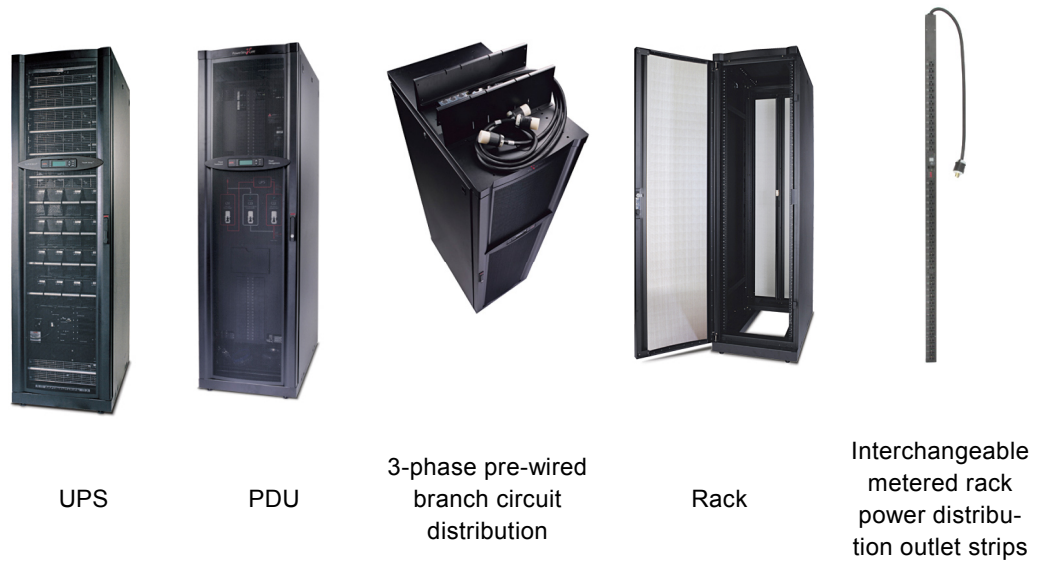

In addition to the capability of the adaptable rack enclosure power system to respond quickly and economically to change, there are cycle time and cost advantages associated with the initial installation of the system, including a dramatic simplification to the up-front engineering and installation work associated with data center design. Furthermore, the ability to adapt the rack enclosure power system can allow the system to be “right sized” to the actual load requirement and grow with expanding needs. The economic benefits of rightsizing can be well over 50% of the lifecycle cost of a data center or network room and are discussed in more detail in APC White Paper 37, *Avoiding Costs from Oversizing Data Center and Network Room Infrastructure*.

Related resource
APC White Paper 37

*Avoiding Costs from
Oversizing Data center and
Network Room Infrastructure*

Conclusion

Individual rack enclosure power consumption in the data center or network room varies widely and is expected to grow in the next few years. Rack enclosure equipment is replaced 5 or more times during the life of a data center in a piecemeal manner. This situation requires a rack enclosure power distribution system that can cope with the changing requirements. Key requirements of an effective rack power distribution system were described, which suggest a practical rack enclosure power architecture that can meet the requirements for an adaptable rack enclosure power system. The recommended approach standardizes on four key ways to distribute power, along with a strategy for selection of the best approach for a given installation. When this approach is implemented, the result is a power distribution system which reduces human error, adapts to changing requirements, minimizes the need for advance planning and meets the requirements of high density IT equipment.



About the author

Neil Rasmussen is the Senior VP of Innovation for APC, which is the IT Business Unit of Schneider Electric. He establishes the technology direction for the world's largest R&D budget devoted to power, cooling, and rack infrastructure for critical networks.

Neil holds 14 patents related to high efficiency and high density data center power and cooling infrastructure, and has published over 50 white papers related to power and cooling systems, many published in more than 10 languages, most recently with a focus on the improvement of energy efficiency. He is an internationally recognized keynote speaker on the subject of high efficiency data centers. Neil is currently working to advance the science of high-efficiency, high-density, scalable data center infrastructure solutions and is a principal architect of the APC InfraStruXure system.

Prior to founding APC in 1981, Neil received his bachelors and masters degrees from MIT in electrical engineering, where he did his thesis on the analysis of a 200MW power supply for a tokamak fusion reactor. From 1979 to 1981 he worked at MIT Lincoln Laboratories on flywheel energy storage systems and solar electric power systems.



Resources

Click on icon to link to resource



Browse all APC
white papers
whitepapers.apc.com



AC vs. DC for Data Centers and Network Rooms

APC White Paper 63



Current Harmonics and Neutral Overloads

APC White Paper 26



Comparing Availability of Various Rack Power Redundancy Configurations

APC White Paper 48



Cooling Strategies for Ultra-High Density Racks and Blade Servers

APC White Paper 46



Re-examining the Suitability of the Raised Floor for Data Center Applications

APC White Paper 19



Dynamic Power Variations in Data Centers and Network Rooms

APC White Paper 43



Avoiding Costs from Oversizing Data Center and Network Room Infrastructure

APC White Paper 37



Standardization and Modularity in Data Center Physical Infrastructure

APC White Paper 116



Browse all APC
TradeOff Tools™
tools.apc.com



Contact us

For feedback and comments about the content of this white paper:

Data Center Science Center, APC by Schneider Electric
DCSC@Schneider-Electric.com

If you are a customer and have questions specific to your data center project:

Contact your **APC by Schneider Electric** representative

Appendix A: detailed analysis of an exhaustive set of rack power delivery options

Various practical circuit types, including multiples, which can provide rack power, are listed in **Table A1**. The table is ranked by increasing rack power capacity.

Table A1

*Characteristics of
rack power circuit
configurations*

Total kW	circuit type	# whips	kW / whip	# poles	kW / pole	max single load kW	# breakers	coordination
2.3	230V 10A	1	2.3	1	2.3	2.3	1	E
3.7	230V 16A	1	3.68	1	3.7	3.68	1	E
4.6	230V 10A	2	2.3	2	2.3	2.3	2	E
5.8	230V 25A	1	5.75	1	5.8	5.75	3	P
6.9	230V 10A	3	2.3	3	2.3	2.3	3	E
6.9	230V/400V 10A 3 ph	1	6.9	3	2.3	2.3	3	E
7.4	230V 32A	1	7.36	1	7.4	7.36	3	G
7.4	230V 16A	2	3.68	2	3.7	3.68	2	E
11.0	230V/400V 16A 3 ph	1	11	3	3.7	3.68	3	E
11.0	230V 16A	3	3.68	3	3.7	3.68	3	E
11.5	230V 25A	2	5.75	2	5.8	5.75	6	P
13.8	230V/400V 10A 3 ph	2	6.9	6	2.3	2.3	6	E
14.7	230V 32A	2	7.36	2	7.4	7.36	6	G
17.3	230V/400V 25A 3 ph	1	17.3	3	5.8	5.75	9	P
17.3	230V 25A	3	5.75	3	5.8	5.75	9	P
20.7	230V/400V 10A 3 ph	3	6.9	9	2.3	2.3	9	E
22.1	230V/400V 32A 3 ph	1	22.1	3	7.4	7.36	9	G
22.1	230V/400V 16A 3 ph	2	11	6	3.7	3.68	6	E
22.1	230V 32A	3	7.36	3	7.4	7.36	9	G
33.1	230V/400V 16A 3 ph	3	11	9	3.7	3.68	9	E
34.5	230V/400V 25A 3 ph	2	17.3	6	5.8	5.75	18	P
44.2	230V/400V 32A 3 ph	2	22.1	6	7.4	7.36	18	G

Fault coordination – legend: E = excellent G = good P = poor

The options described in **Table A1** are limited to a maximum of 3 whips, and includes only multiples where all of the whips are of the same circuit configuration. Dedicated whips may be some mixed combination of the whips in the above list per rack.

While this list is exhaustive, certain combinations can be eliminated if the objective is to provide power to high density rack enclosures. A power system for high density loads should also be able to power single loads of at least 3 kW since there are many high density loads that require up to 3 kW. In most 230V countries, virtually all branch circuits feeding rack enclosures are rated for 16A equipment. Given this, the 10A whip options can be eliminated. In addition, a power system for high density loads should not exhibit a poor breaker coordination ratio. By excluding options that do not meet these criteria, the list of **Table A1** is reduced to the list of **Table A2**.

Table A2

Characteristics of rack power circuit configurations suitable for high density loads

Total kW	circuit type	# whips	kW / whip	# poles	kW / pole	max single load kW	# breakers	coordination
3.7	230V 16A	1	3.68	1	3.7	3.68	1	E
7.4	230V 32A	1	7.36	1	7.4	7.36	3	G
7.4	230V 16A	2	3.68	2	3.7	3.68	2	E
11.0	230V/400V 16A 3 ph	1	11	3	3.7	3.68	3	E
11.0	230V 16A	3	3.68	3	3.7	3.68	3	E
14.7	230V 32A	2	7.36	2	7.4	7.36	6	G
22.1	230V/400V 32A 3 ph	1	22.1	3	7.4	7.36	9	G
22.1	230V/400V 16A 3 ph	2	11	6	3.7	3.68	6	E
22.1	230V 32A	3	7.36	3	7.4	7.36	9	G
33.1	230V/400V 16A 3 ph	3	11	9	3.7	3.68	9	E
44.2	230V/400V 32A 3 ph	2	22.1	6	7.4	7.36	18	G

Fault coordination – legend: E = excellent G = good P = poor