

Fundamental Principles of Air Conditioners for Information Technology

White Paper 57

Revision 3

by Tony Evans

> Executive summary

Every IT professional who is responsible for the operation of computing equipment needs to understand the function of air conditioning in the data center or network room. This introductory paper explains the function of basic components of an air conditioning system for a computer room. The concepts presented here are a foundation for allowing IT professionals to successfully specify, install, and operate critical facilities.

Contents

Click on a section to jump to it

Introduction	2
The nature of heat in the IT environment	2
The refrigeration cycle	3
Energy used by the refrigeration cycle	5
Application of the refrigeration cycle in IT cooling	5
Variations of the refrigeration cycle in IT cooling	7
Conclusion	7
Resources	8

Introduction

Whenever electrical power is being consumed in an Information Technology (IT) room or data center, heat is being generated that needs to be removed from the space. Data center and IT room heat removal is one of the most essential yet least understood of all critical IT environment processes. Improper or inadequate cooling significantly detracts from the lifespan and availability of IT equipment. A general understanding of the fundamental principles of air conditioning and the basic arrangement of precision cooling systems facilitates more precise communication among IT and cooling professionals when specifying, operating, or maintaining a cooling solution.

This paper explains the basic operating principles and major components of precision cooling systems from an IT perspective. It also provides basic concepts that are an essential foundation for the proper specification and design of data centers or network rooms. This is an introductory paper from a suite of related papers on more advanced cooling topics from APC by Schneider Electric, and provides references for readers interested in a more complete treatment of the subject.

The nature of heat in the IT environment

Heat is simply a form of energy. In the data center heat is produced as electricity is consumed by IT equipment. With few exceptions, over 99% of the electricity used to power IT equipment is converted into heat. Unless the excess heat energy is removed, room temperature will rise until IT equipment fails. Approximately 50% of the heat energy released by servers originates in the microprocessor itself. A fan moves a stream of cooling air across the chip assembly. The server or rack-mounted blade assembly containing the microprocessors usually draws cooling air into the front of the chassis and exhausts it out of the rear as shown in **Figure 1**. The amount of heat generated by servers is on a rising trend. A single blade server chassis can release 4 Kilowatts (kW) of heat energy into the IT room or data center. Such a heat output is equivalent to the heat released by forty 100-Watt light bulbs and is actually more heat energy than the capacity of the heating element in many residential cooking ovens.

Figure 1

Microprocessor and server cooling airflow

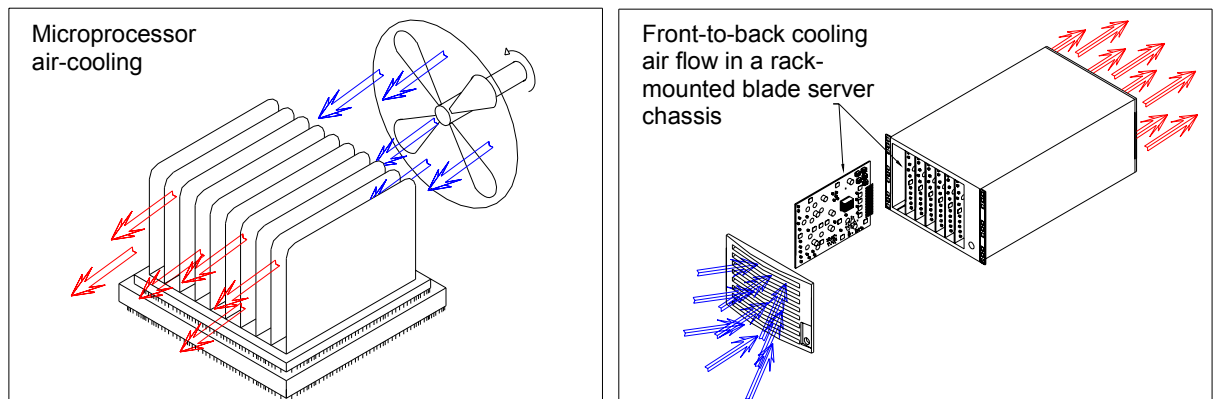

A unique property of heat energy is that it can only flow in one direction, from hot to cold. For example a cold object placed in a hot room cannot drop in temperature it can only gain heat energy and rise in temperature. It is for this reason that air conditioners and refrigerators exist. They use electrical or mechanical energy to *pump* heat energy from one place to another, and are even capable of pumping heat from a cooler space to a warmer space. The ability to pump heat to the outdoors, even when it is hotter outside than it is in the data center, is a critical function that allows high-power computing equipment to operate in an

enclosed space. Understanding how this is possible is a foundation to understanding the design and operation of cooling systems for IT installations.

The refrigeration cycle

The actual movement of heat energy from the IT room to the outside atmosphere is achieved by use of the refrigeration cycle. It's the same process today that has been used for over 100 years. The refrigeration cycle is a closed cycle of evaporation, pressure change, condensation, and flow regulation applied to a fluid called refrigerant. **Figure 2** shows the refrigeration cycle and its key components as they are applied to a typical IT environment. The specific processes and components are described below.

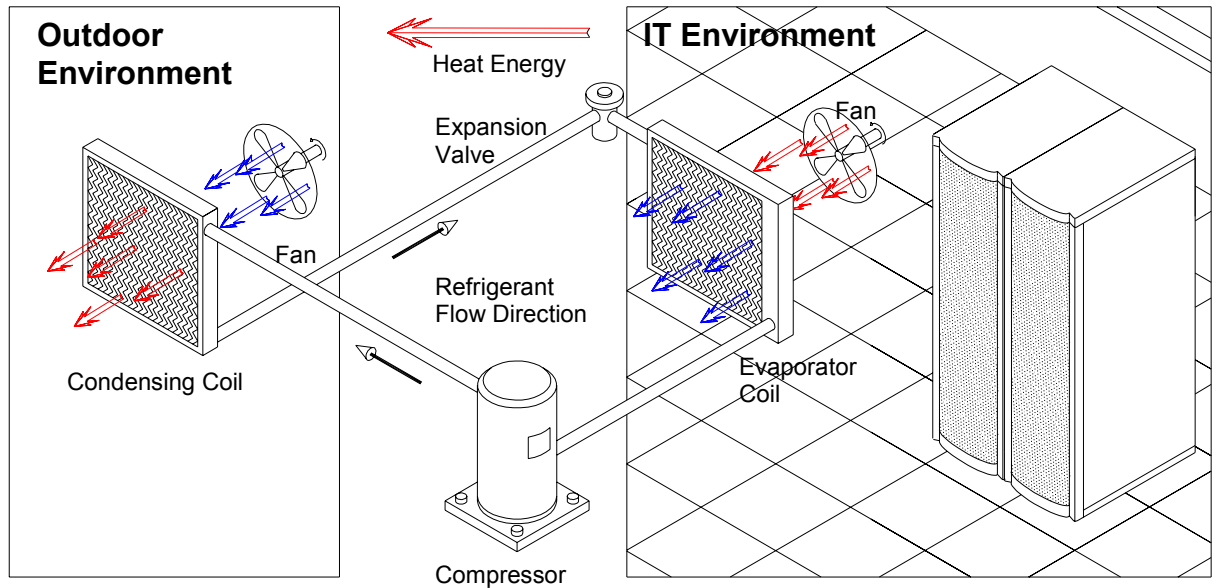

Figure 2
Heat energy removal via the refrigeration cycle

Evaporation

Evaporation is the first step in removing heat energy from a computer room. The evaporator coil acts like an automobile radiator operating in reverse. Warm air from the computer room is blown across the evaporator coil by a fan, while the pipes comprising the coil are supplied with cold liquid refrigerant. (How the refrigerant comes to be cool is described later in the sequence). When the warm computer room air passes through the cold evaporator coil it is cooled and this cool air is delivered back to the computer room.

Even though the evaporator coil is cold, at approximately 46°F (7.8°C), the refrigerant inside is evaporating, or boiling, changing from liquid to a gaseous state.¹ It is the heat from the computer room that is boiling the refrigerant, passing heat energy to the refrigerant in the process. The refrigerant at this point is a cool gas in a small pipe that is carrying the heat energy away from the computer room.

Compression

The vaporized but cool refrigerant carrying the heat from the data center is drawn into a compressor, as shown in **Figure 2**. This compressor has two important functions:

¹ Most people are familiar with water boiling at 212°F (100°C). How does refrigerant boil at 46°F? Every substance has a unique boiling temperature based on its composition and pressure. Air conditioning systems are engineered to boil refrigerant at approximately 46F by carefully regulating pressure. Refrigeration systems boil refrigerant at much lower temperatures in the same manner.

1. It pushes the refrigerant carrying the heat energy around the refrigeration loop.
2. It compresses the gaseous refrigerant from the evaporator coil to over 200 psi or 1379 kPa².

It is a fundamental property of gases that the compression of a gas causes its measured temperature to rise. Therefore, the moving gaseous refrigerant exiting the compressor is hot, over 125°F (52°C), as well as compressed. This temperature rise due to compression is the key to the ability of the refrigeration loop to eject heat into the outdoor environment.

Condensation

The hot compressed refrigerant carries the computer room heat energy from the compressor to the condenser coil. Like the evaporator coil, this coil transfers heat to another medium, like air. But unlike the evaporator coil which was LOWER in temperature than the air flowing across the coil, the condenser coil operates at a temperature HIGHER than the air. This means that the air flowing across the coil is heated by the coil, and that the hot gaseous refrigerant flowing through the coil is conversely cooled. Heat is flowing from the refrigerant to the air. The air is typically blown across the hot coil by a fan which exhausts the hot air to the outdoors. In this way heat energy from the computer room has been pumped outdoors.

Expansion

The refrigerant exits the condenser coil as a hot, high-pressure liquid. The refrigerant is then piped to a device called an expansion valve positioned at the entrance to the evaporator coil. This valve has two key functions that are critical to the refrigeration cycle:

1. It precisely regulates the flow of high-pressure refrigerant into the low-pressure evaporator coil at a rate that maintains an optimal difference in pressure to ensure all refrigerant is evaporated prior to leaving the coil.
2. The refrigerant again becomes capable of being expanded (boiled) to a gas by the heat energy in the data center as it escapes the expansion valve and re-enters the evaporator coil.

In this way the refrigeration cycle is repeated, and the net result of the process is that heat is continuously flowing into the evaporator coil and continuously flowing out of the condenser coil. An air conditioner system operated in this way will continuously pump heat energy out of the computer room.

Refrigerants

All air conditioners contain a volume of fluid known as refrigerant. Refrigerant is the substance used to actually transport heat from the IT environment to the outside environment. Many common substances have been used as refrigerants to include ammonia, carbon dioxide, air and water. Modern systems usually use fluorinated hydrocarbons that are nonflammable and nontoxic. These refrigerants are commonly referred to by their ASHRAE (American Society of Heating, Refrigeration, and Air Conditioning Engineers) numerical designation. Older systems use a refrigerant designated R-12 that has been banned from future use due to environmental concerns of ozone depletion. Today the most commonly used refrigerant in the IT environment is R-22. Legislation exists that bans the production of equipment using R-22 in 2010. It is likely that cooling equipment manufacturers will produce equipment using alternate environmentally compliant refrigerants like R-134a in the near

² Psi = pounds per square inch

kPa = kilopascals

future. IT professionals and cooling professional should work together to ensure the choice of cooling equipment and refrigerant reflects environmental policy and the expected service life of the equipment.

Energy used by the refrigeration cycle

Related resource
APC White Paper 25

Calculating Total Cooling Requirements for Data Centers

The pumping of heat energy from the computer room requires electrical energy. But to know how much electrical energy is required, you must first know how much heat energy is produced in the IT environment. This is the subject of APC White Paper 25, *Calculating Total Cooling Requirements for Data Centers*. In a computer room, the amount of electrical energy consumed is roughly the same amount of heat energy produced which is roughly equal to the cooling capacity required. This fact has led to the rating of precision air conditioners in kW verses the traditional Btu/hr.

The amount of electrical energy required to cool a computer room can be readily estimated. The fans that circulate the air through the evaporator and condenser coils require electrical power approximately equivalent to 5-10% of the rated cooling capacity in kW. The compressor requires electrical power approximately equivalent to 20-30% of the rated cooling capacity in kW. This means that for every 1000 Watts of heat energy removed from the computer room, approximately 350 Watts of electrical power is needed to run the air conditioner. Unfortunately, for reasons discussed in other APC white papers, typical computer room air conditioners operate much less efficiently than their design values. The actual electrical power needed to run typical, poorly designed, air conditioning systems is approximately equal to the cooling capacity being handled.

For a discussion on air conditioning efficiency in mission critical facilities see the following papers (links in **Resources** section at end of paper):

APC White Paper 49, *Avoidable Mistakes that Compromise Cooling Performance in Data Centers and Network Rooms*

APC White Paper 44, *Improving Rack Cooling Performance Using Blanking Panels*

Application of the refrigeration cycle in IT cooling

Related resource
APC White Paper 56

How and Why Mission Critical Cooling Systems Differ from Common Air Conditioners

IT rooms and data centers are usually cooled with specialized air conditioning equipment commonly called "precision cooling systems". These systems differ from typical residential or commercial air conditioning systems in that they provide more precise, stable environments for IT equipment by closely regulating air temperature and moisture (See APC White Paper 56, *How and Why Mission Critical Cooling Systems Differ from Common Air Conditioners*, for information detailing the characteristics and capabilities of precision cooling systems).

Figure 3

Typical heat removal and heat rejection components

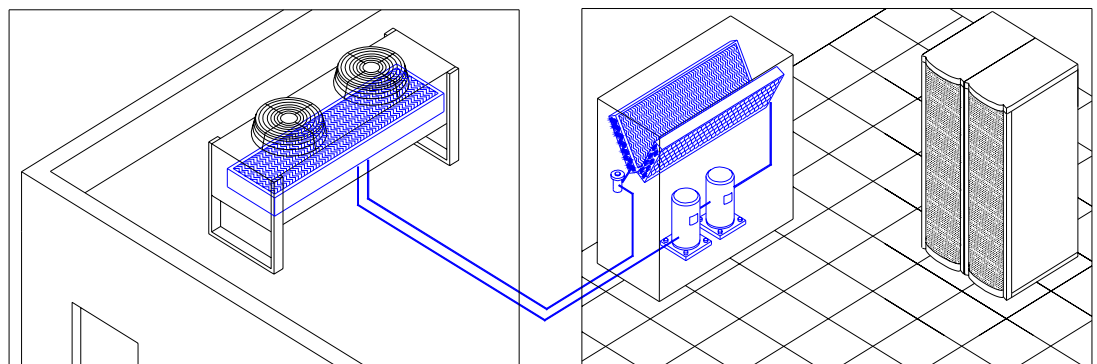

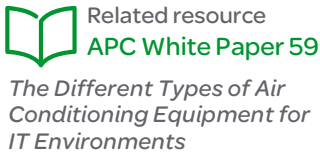

Equipment located inside the IT environment

Common configurations for precision cooling systems in the IT room or data center include large floor-mounted computer room air conditioners (CRAC), computer room air handlers (CRAH), ceiling-mounted air conditioners, and portable air conditioners known as “spot coolers”. See APC White Paper 59, *The Different Types of Air Conditioning Equipment for IT Environments* for more information on these different heat removal devices. Any typical computer room air conditioner is expected to provide cold air however there are several additional inputs, outputs and connections IT professionals should be aware of as the failure of any of them can lead to IT equipment failure. One floor-mounted computer room air conditioning system as shown in **Figure 3** typically removes 35-150 kW of heat energy from the IT environment. Selected inputs, outputs and physical characteristics of a system designed to remove 50 kW of heat energy are described below:

- Over 8000 cubic feet of air (226.5 cubic meters) at a specific temperature and moisture level enter the air conditioner from the data center every minute. That’s more than the volume inside two tractor-trailers.
- The same volume of air exits the air conditioner each minute at a new, user-set temperature and moisture level.
- The air conditioner consumes approximately 30 kW of three-phase electrical energy. (This heat energy is removed by the air conditioner itself and is not added to the IT environment).
- Two 1-inch (25 millimeters) diameter (approximate) pipelines supply and return refrigerant to the outdoor heat rejection device.
- A 7/8-inch (22.2 millimeter) diameter pipe transports water the air conditioner removes from the air to a building drain. This is known as a condensate line.
- A 1/4-inch (6.4 millimeter) diameter pipe from the building’s drinking water supply allows water vapor to be added to the air leaving the air conditioner to regulate humidity.
- The air conditioner itself is 70 inches long, 35 inches deep, 76 inches high (about the size of three IT equipment rack enclosures) and weighs 1350 pounds (612kg). (178cm x 89cm x 193cm)

Equipment located outside the IT environment

IT professionals are usually familiar with the presence of computer room air conditioners or air handlers in the IT room or data center. They are generally less familiar with the other half of the cooling system - the outdoor heat rejection device. With the exception of some ceiling-mounted and portable air conditioners, there are always one or more major components essential to the cooling system existing outside of the IT environment. The function of these devices is to transfer the heat pumped from the IT environment to the outside atmosphere. The computer room air conditioner detailed in the previous section requires a device called an air-cooled condenser to reject the heat from the IT environment to the outside atmosphere. Selected characteristics of an air-cooled condenser compatible with the computer room air conditioner shown in **Figure 3** are described below:

- The device is 10 feet long, 4 feet high, 4 feet wide (304cm x 122cm x 122cm) and weighs 900 pounds (408kg).
- It receives the two refrigerant pipes run from the computer room air conditioning unit located in the IT environment.
- Over 20,000 cubic feet (566 cubic meters) of outdoor air pass through the air-cooled condenser each minute to receive the heat energy transferred from the IT environment.
- It must be secured outdoors to a roof or concrete pad.

- The air-cooled condenser consumes approximately 5 kW of three-phase electrical energy.

Variations of the refrigeration cycle in IT cooling



Related resource
APC White Paper 59

The Different Types of Air Conditioning Equipment for IT Environments

The previous section detailed the characteristics of an air-cooled computer room air conditioning (CRAC) system and its associated heat rejection components. There are several other cooling system configurations routinely installed in IT rooms and data centers that IT professionals should be aware of. All utilize the refrigeration cycle and ultimately reject heat to the outside atmosphere. A guide to these various configurations of IT room and data center cooling is provided in APC White Paper 59, *The Different Types of Air Conditioning Equipment for IT Environments*.

Conclusion

Cooling systems for data centers and IT rooms utilize the refrigeration cycle to remove heat energy generated by IT equipment. Inadequate or unreliable cooling solutions jeopardize the availability of the space by increasing the risk of thermally induced downtime. IT professionals versed in precision cooling mechanisms, components and configurations can more effectively work with cooling professionals to ensure the specification and purchase of optimized cooling solutions.



About the author

Tony Evans is an engineer with APC by Schneider Electric in West Kingston, RI. He has 14 years of experience in power and cooling system design and is a member of ASHRAE Technical Committee 9.9 (Mission Critical Facilities, Technology Spaces, & Electronic Equipment).



Resources

Click on icon to link to resource



Calculating Total Cooling Requirements for Data Centers

APC White Paper 25



How and Why Mission Critical Cooling Systems Differ from Common Air Conditioners

APC White Paper 56



Browse all APC white papers
whitepapers.apc.com



Avoidable Mistakes that Compromise Cooling Performance in Data Centers and Network Rooms

APC White Paper 49



Improving Rack Cooling Performance Using Blanking Panels

APC White Paper 44



The Different Types of Air Conditioning Equipment for IT Environments

APC White Paper 59



Browse all APC TradeOff Tools™
tools.apc.com



Contact us

For feedback and comments about the content of this white paper:

Data Center Science Center, APC by Schneider Electric
DCSC@Schneider-Electric.com

If you are a customer and have questions specific to your data center project:

Contact your **APC by Schneider Electric** representative